





Cable Drums

Description:

OPTOKON offers complimentary high quality deployable cable drums. Users can select the appropriate design and style for their particular application. The drums are ideally suited to Military, Industrial, Broadcast and pro Audio applications. All drums are supplied with a third flange allowing full access to each end of the cable assembly.

The drums are delivered in standard black color RAL 9005 mat. Other - green khaki RAL 6014 mat color is available upon request¹.

<p>BBD-500NR, BBD-1000, BBD-1500N - (6014¹)</p> <p>Heavy duty drum with direct crank rewind permanently attached to the axle. Designed for installation on military vehicle or TBD-500 type trolley suitable for mobile applications.</p>	 <p>BBD-1000</p>
<p>TBD-500NR - (6014¹)</p> <p>Trolley drum with one-piece foot, rubber tyres and removable steel handlebars for long term shipping and storage. Large wheel diameter allows easy field operations.</p>	 <p>BBD-500NR TBD-500NR-6014</p>
<p>SBD-200 - (6014¹)</p> <p>Small, lightweight and durable design for quick and easy use, ideal for applications where 200 m lengths of cable are deployed out over large areas.</p>	 <p>SBD-200-6014</p>
<p>MBD-200, MBD-500 - (6014¹)</p> <p>These reels are stackable for maximum transport and storage efficiency, rugged steel construction throughout, including square tubular frame.</p>	 <p>MBD-500</p>
<p>RBD-200, RBD-500 - (6014¹)</p> <p>Mobile drum, with strap belts for shoulder wear. Suitable for use in the field. Weight with HMA connectors 200 m cable is 15 kg. The drum is available in two versions, for 200 m and 500 m of 5.5 mm tactical cable.</p>	 <p>RBD-200-6014 RBD-500</p>

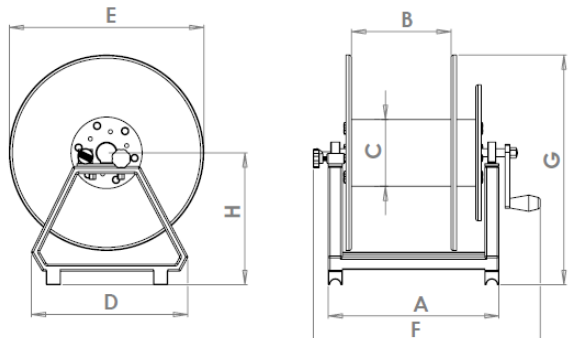
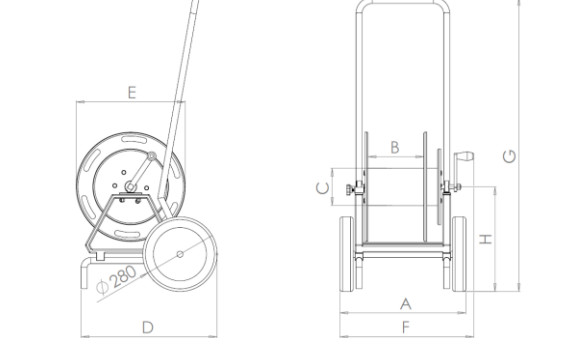
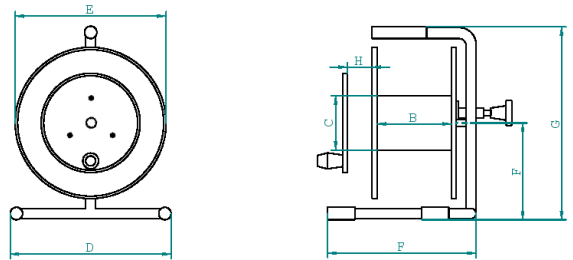
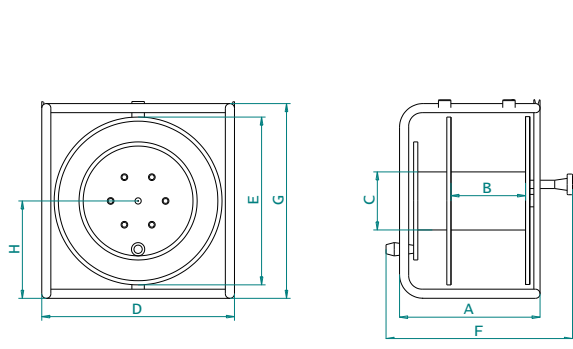
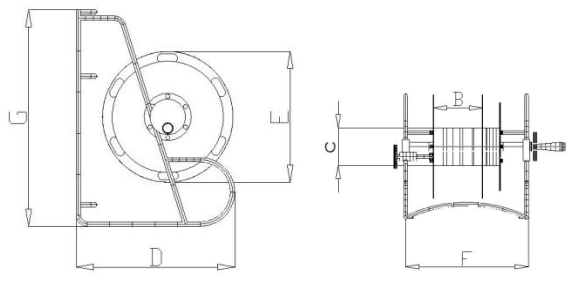
<p>BBD-500NR, BBD-1000, BBD-1500N</p> <p>The drum BBD-500NR is designed for winding of up to 500 m cable diameter 5.5 mm. Type BBD-1000/1500N is wider and allows storage up to 1/1.5 km cable diameter 5.5 mm.</p> <p>Weight: BBD-500NR:11.4 kg, BBD-1000:13.3 kg, BBD-1500N:15.5 kg</p> <table border="1"> <thead> <tr> <th colspan="8">Reel Dimensions BBD-500NR, BBD-1000/1500N (mm)</th> </tr> <tr> <th>A</th> <th>B</th> <th>C</th> <th>D</th> <th>E</th> <th>F</th> <th>G</th> <th>H</th> </tr> </thead> <tbody> <tr> <td>360</td> <td>210</td> <td>140</td> <td>330</td> <td>410</td> <td>480</td> <td>490</td> <td>280</td> </tr> <tr> <td>600</td> <td>450</td> <td>140</td> <td>330</td> <td>410</td> <td>690</td> <td>490</td> <td>280</td> </tr> <tr> <td>780</td> <td>630</td> <td>140</td> <td>330</td> <td>410</td> <td>890</td> <td>490</td> <td>280</td> </tr> </tbody> </table>	Reel Dimensions BBD-500NR, BBD-1000/1500N (mm)								A	B	C	D	E	F	G	H	360	210	140	330	410	480	490	280	600	450	140	330	410	690	490	280	780	630	140	330	410	890	490	280	
Reel Dimensions BBD-500NR, BBD-1000/1500N (mm)																																									
A	B	C	D	E	F	G	H																																		
360	210	140	330	410	480	490	280																																		
600	450	140	330	410	690	490	280																																		
780	630	140	330	410	890	490	280																																		
<p>TBD-500NR</p> <p>The BBD drum is installed on a mobile chassis.</p> <p>Weight: TBD-500NR: 23 kg</p> <table border="1"> <thead> <tr> <th colspan="8">Reel Dimensions TBD-500NR (mm)</th> </tr> <tr> <th>A</th> <th>B</th> <th>C</th> <th>D</th> <th>E</th> <th>F</th> <th>G</th> <th>H</th> </tr> </thead> <tbody> <tr> <td>470</td> <td>210</td> <td>140</td> <td>510</td> <td>410</td> <td>500</td> <td>1090</td> <td>390</td> </tr> </tbody> </table>	Reel Dimensions TBD-500NR (mm)								A	B	C	D	E	F	G	H	470	210	140	510	410	500	1090	390																	
Reel Dimensions TBD-500NR (mm)																																									
A	B	C	D	E	F	G	H																																		
470	210	140	510	410	500	1090	390																																		
<p>SBD-200</p> <p>For a typical cable diameter of 5.5 mm, the SBD drum will accept 250 m of cable.</p> <p>Weight: SBD-200: 6.2 kg</p> <table border="1"> <thead> <tr> <th colspan="8">Reel Dimensions SBD-200 (mm)</th> </tr> <tr> <th>B</th> <th>C</th> <th>D</th> <th>E</th> <th>F</th> <th>G</th> <th>H</th> <th></th> </tr> </thead> <tbody> <tr> <td>200</td> <td>110</td> <td>325</td> <td>305</td> <td>300</td> <td>390</td> <td>30</td> <td></td> </tr> </tbody> </table>	Reel Dimensions SBD-200 (mm)								B	C	D	E	F	G	H		200	110	325	305	300	390	30																		
Reel Dimensions SBD-200 (mm)																																									
B	C	D	E	F	G	H																																			
200	110	325	305	300	390	30																																			
<p>MBD-200, MBD-500</p> <p>Two different drums dimensions. The MBD-200 drum will accept 200 m, the MBD-500 up to 500 m cable of 5.5 mm diameter.</p> <p>Weight: MBD-200: 8.0 kg, MBD-500: 10.8 kg</p> <table border="1"> <thead> <tr> <th colspan="8">Reel Dimensions MBD-200, MBD-500 (mm)</th> </tr> <tr> <th>A</th> <th>B</th> <th>C</th> <th>D</th> <th>E</th> <th>F</th> <th>G</th> <th>H</th> </tr> </thead> <tbody> <tr> <td>290</td> <td>200</td> <td>110</td> <td>375</td> <td>305</td> <td>385</td> <td>370</td> <td>185</td> </tr> <tr> <td>340</td> <td>210</td> <td>140</td> <td>465</td> <td>410</td> <td>420</td> <td>470</td> <td>235</td> </tr> </tbody> </table>	Reel Dimensions MBD-200, MBD-500 (mm)								A	B	C	D	E	F	G	H	290	200	110	375	305	385	370	185	340	210	140	465	410	420	470	235									
Reel Dimensions MBD-200, MBD-500 (mm)																																									
A	B	C	D	E	F	G	H																																		
290	200	110	375	305	385	370	185																																		
340	210	140	465	410	420	470	235																																		
<p>RBD-200, RBD-500</p> <p>For a typical cable diameter of 5.5 mm, the RBD drum will accept 200 m, the RBD-500 up to 500 m of cable.</p> <p>Weight: RBD-200: 9.7 kg, RBD-500: 10.7 kg</p> <table border="1"> <thead> <tr> <th colspan="8">Reel Dimensions RBD-200, RBD-500 (mm)</th> </tr> <tr> <th>A</th> <th>B</th> <th>C</th> <th>D</th> <th>E</th> <th>F</th> <th>G</th> <th>H</th> </tr> </thead> <tbody> <tr> <td>-</td> <td>200</td> <td>110</td> <td>310</td> <td>305</td> <td>360</td> <td>570</td> <td>-</td> </tr> <tr> <td>-</td> <td>325</td> <td>110</td> <td>320</td> <td>305</td> <td>430</td> <td>570</td> <td>-</td> </tr> </tbody> </table>	Reel Dimensions RBD-200, RBD-500 (mm)								A	B	C	D	E	F	G	H	-	200	110	310	305	360	570	-	-	325	110	320	305	430	570	-									
Reel Dimensions RBD-200, RBD-500 (mm)																																									
A	B	C	D	E	F	G	H																																		
-	200	110	310	305	360	570	-																																		
-	325	110	320	305	430	570	-																																		

Note: 1) Standard black color RAL 9005 mat, use code -6014 if green khaki RAL 6014 mat color is required.
2) Dimensions tolerance: ±20 mm